

GAS – T1 (Propane Detector) Users Manual

The gas detector is a device that signals the presence of a certain type of gas with the help of a local alarm and warning light. The device can function alone or be controlled by the control unit from which it can view the sensor status (Alarm ON, OFF, preheating) and control the turning on, turning off and deactivation of the local alarm. Inside the device there is a two-position relay that is released when alarm conditions occur.

Bear in mind that in the case of propane, installation is recommended on the lower part of the camper.

Installing the GAS SENSORS on the D2NA and NNA systems

This applications note describes the procedure to follow when there is the need to install a gas sensor on the electrical system of a mobile home of the D2NA type (Production 1999-2000) and on that of the NNA type (Production 1998-1999).

Installation on D2NA system

There are two possible types of installation: two-wire or four-wire.

The first type of installation, with two wires (positive and negative 12 V power supply wires), makes it possible to use the device through its local commands and signals; the second type of installation, with four wires (positive and negative 12 V power supply and A and B communication wires), allows you to use the device with its local functions and control and observe its status directly from the control panel.

For this function the control unit must be of the LCD model with software version Rel. 1.26 or later.

For control units with earlier software versions, it is possible to have upgrades.

Type of installation

The types of installation possible may be the ones shown in Figure 1 and Figure 2. The highlighted part is already present on board the vehicle; the connection cable between the sensor and the distribution part is a four-conductor cable of the same type as those used for the electrical system of the D2NA system.

The conductor section recommended for the connection is 0.75 mm².

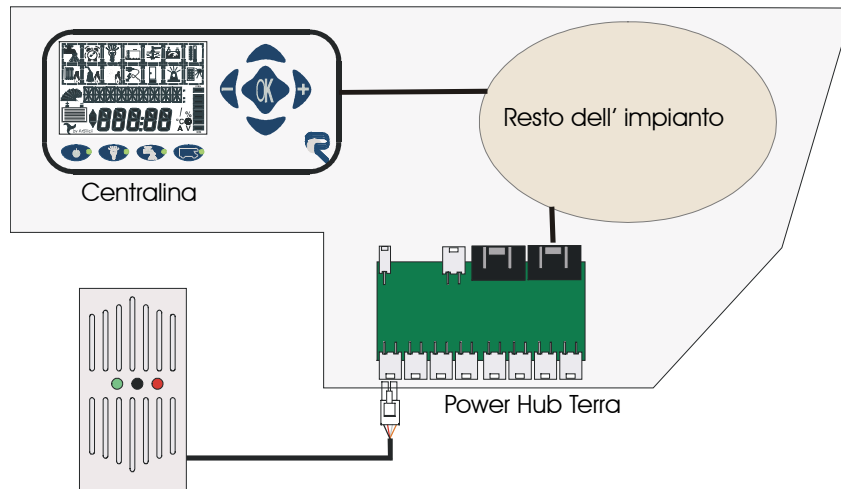

Figure 1 "Installing sensor on D2NA system under General"

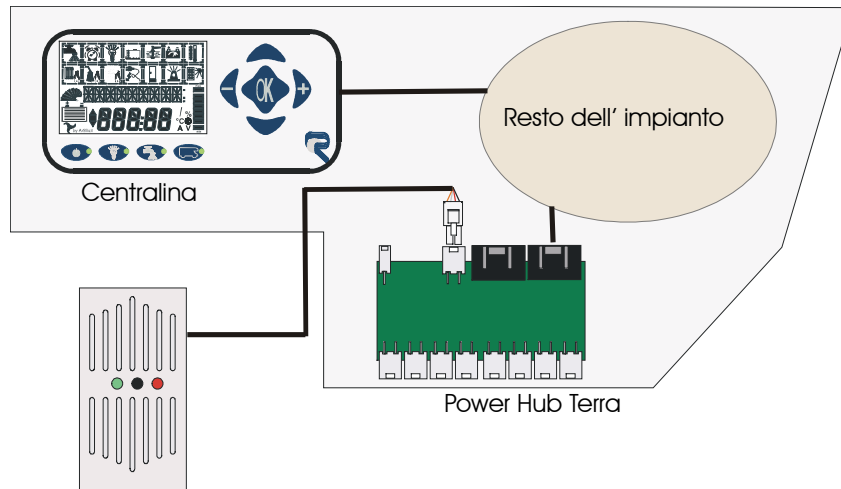

Figure 2 " Installing sensor on D2NA system outside of General "

Installation on NNA system

In this case too there are two possible types of installation: two-wire or four-wire. The first type of installation, with two wires (positive and negative 12 V power supply wires), makes it possible to use the device through its local commands and signals; the second type of installation, with four wires (positive and negative 12 V power supply and A and B communication wires), allows you to use the device with its local functions and control and observe its status directly from the control panel. For this function the control unit must be of the LCD model with software version Rel. 1.26 or later. For control units with earlier software versions, it is possible to have upgrades.

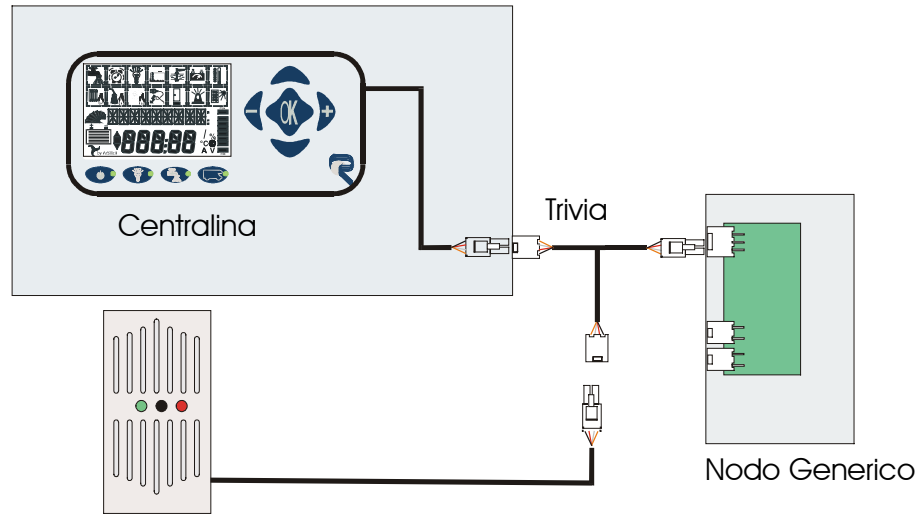

Figure 3 " Installation of sensor on NNA system"

Figure 3 shows the installation diagram.

The highlighted part is already present on board the vehicle; the connection cable between the sensor and the distribution part is a four-conductor cable of the same type as those used for the electrical system of the NNA and D2NA systems.

The conductor section recommended for the connection is 0.75 mm^2 .

HOW TO USE IT

The sensor has a pushbutton, a green LED and a red LED.

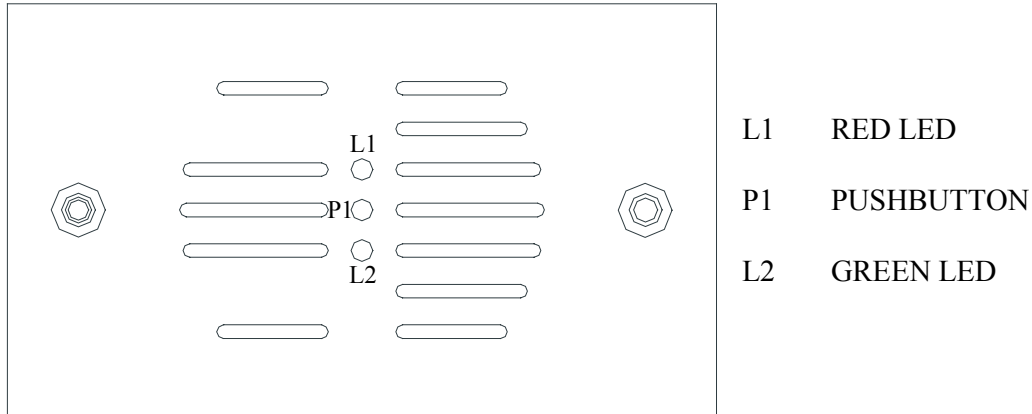

Turning ON/OFF

To turn the sensor ON and OFF, just press the pushbutton at the centre of the sensor between the two LEDs, or from the control unit menu with the “Sensor ON” or “Sensor OFF” command. When it turns on, the two LEDs and the buzzer turn on simultaneously as an initial test to check their operation.

Pre-heating

Right after they are turned on there is a preheating phase during which the measuring sensor must reach normal operating conditions; during this process, which lasts about 90 seconds, the sensor cannot detect gas leaks. Pre-heating is indicated by the flashing green LED and by the control unit with the flashing word “ON”. When the sensor is operative the green LED stops flashing, as does the word “ON” on the control unit.

GAS leak alarm

This device operates when the green LED is on. In an alarm situation, the red LED turns on, a buzzer on the sensor sounds, the internal relay is released, and on the control unit the bars appear around the icon and the word GAS appears on the menu. When normal conditions are reset, the red LED turns off, the buzzer stops sounding, the relay returns to a state of rest and on the control unit the bars and the word GAS disappear.

Malfunction

When the sensor is no longer able to detect gas with the due safety features, the red LED flashes. **When the red LED flashes, the sensor is no longer able to provide a correct signal.** In any case, once in a while it is advisable to check operation, for example of the LPG sensor by letting gas out of a cigarette lighter and making it enter the sensor through the slits.

Using the internal relay

Inside the sensor there is a two-position relay that is normally closed and normally open. To connect a device to the relay, you must open the box and insert the wires into the appropriate screw container. The printout shows the connections in relation to the central pole. NC normally closed and NA normally open.

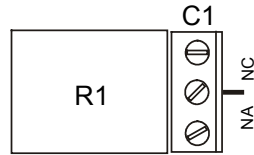

- C1 Terminal Block Connector
- R1 Continuous Relays (5A).

Using several sensors

In this system it is possible to connect up to a maximum of three sensors that can be controlled by the control unit. The devices installed must be different from one another, otherwise the rest of the system might function improperly. To make the devices different, it is necessary to configure the two J1 jumpers.

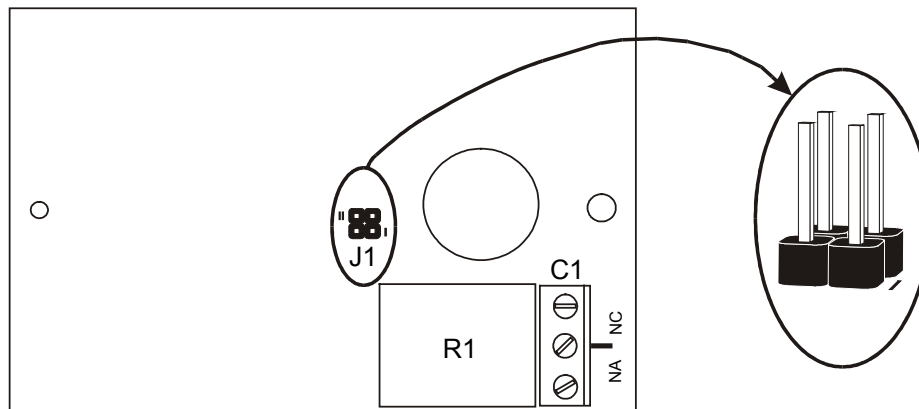

The sensors inserted must have the following configuration:

The first sensor connected to the system must always be without a JUMPER.

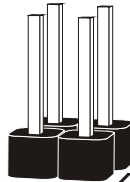

The second sensor connected to the system must always have the JUMPER on the contacts determined by the Roman numeral I.

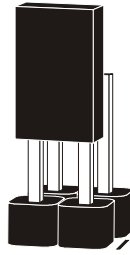

The third sensor connected to the system must always be with the JUMPER on the contacts indicated by the Roman numeral II.

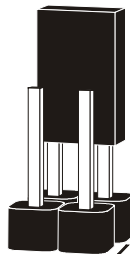

When more than one sensor is connected, the following information is displayed by the control unit:

Sensor ON	If at least one sensor is on.
Sensor ON flashing	If at least one sensor is in the pre-heating phase.
Sensor OFF	If all the sensors are off.
GAS Sensor	If at least one sensor is in a state of alarm.

However, the commands sent by the control unit will be valid for all the sensors:

Sensor ON	Turns on all sensors.
Sensor OFF	Turns off all sensors.
Alarm OFF	Disables all local buzzers.
Alarm ON	Enables all local buzzers.

Sensors not controlled by the system

In the system there is the possibility to insert an indefinite number of “invisible” sensors in the control unit. They are called invisible because the control unit cannot detect them. For this purpose it is necessary to configure jumper J1 on contacts I and II.

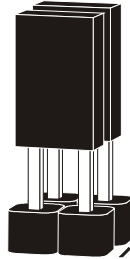

Precautions

The sensor that detects the gas needs particular attention to prevent irreversible malfunctioning:

1. It must not be exposed to silicone vapours because they might irreversibly inhibit it.
2. It must not be placed in corrosive environments of H₂S, SO_x, Cl₂, HCl, etc. where it could break due to the corrosion of the conducting and heating materials.
3. It must not be exposed to contamination from alkaline metals, such as brackish water.
4. Contact with water causes a sensor drift phenomenon, thus compromising the accuracy of the measurements.

Furthermore it is advisable to avoid the following situations:

1. The formation of water condensation on the surface for a long period of time.
2. Using it with a high densities of gas or in saturated environments.
3. Subjecting the sensor to impacts or anomalous vibrations.
4. Prolonged exposure to harsh environments such as high humidity, extreme temperatures, or high levels of contamination.